



Made in the U.S.A.



1-hr fire rated



30 ft impact rated



1/2-hr ETL rating



ETL water resistant



high-security key lock

# SPECIFICATIONS

## VERTICAL LEGAL FILES

**FIRE RESISTANT INSULATION** is 100% gypsum, reinforced by a 1" by 2" lattice made of 14-gauge galvanized welded steel wire, providing complete peace of mind from fire, impact, or explosion.

**FIELD REPLACEABLE STEEL PANELS** can easily be replaced in the event that any panel is damaged.

**FINISH** is an environmentally-friendly electrostatic powder coating applied to all sides, including bottom. The finish is scratch-resistant, providing a lifetime quality appearance. Standard colors available include: arctic white, ivory white, parchment, tan, taupe, brown, black, sand, champagne, platinum, and pewter.

**DRAWER BODIES** are built with high sides for use with hanging folders – no additional frames are needed. Each file includes 1 follower block per drawer.

**DRAWER SUSPENSIONS** are maintenance free.

**DRAWER LOCKS** are UL-listed Medeco high-security key locks.

**DRAWER PULLS** are surface mounted to allow for extra insulation inside the drawer heads.

**INSULATION BETWEEN ALL DRAWERS** makes each drawer a separate insulated container.

**ETL WATER RESISTANCE** Verified to prevent water damage resulting from sprinklers and fire hoses.

**2-POSITION DRAWER CATCH** allows access to certain drawers while others remain locked.

**DRAWER HEADS** are formed of welded steel and filled with fire resistant insulation, and are field replaceable.

**UNDERWRITERS LABORATORIES' (UL) FIRE & IMPACT RATING** on all file cabinets.

These models carry the 1-Hour Class 350 Fire with Impact UL label. Tests include 1 hour exterior fire exposure at 1700°F, a 2000°F explosion test, and a 30 foot drop to test impact integrity.

**ETL 30 MINUTE FIRE** Verified to protect hard drives, CD's, DVD's and thumbdrives.

**OPTIONAL UPGRADES** are available to enhance your file's appearance or functionality.

Upgrades available include custom color finishes, standard lock options, casters, and interior options such as document inserts, trays, and inner drawers.

**FIREKING'S LIMITED LIFETIME WARRANTY** on all mechanical or operable parts.

Associated labor costs will be paid by FireKing for two years from the date of purchase (with authorization in advance). If your FireKing file sustains any damage while protecting documents from a fire, FireKing will replace the file free of charge and ship it freight collect to original owner. For more details visit [www.fireking.com](http://www.fireking.com).

Filing Arrangements:

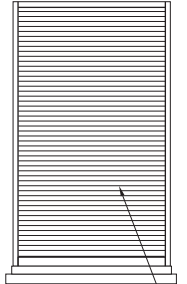

LEGAL FILING FRONT TO BACK

HANGING FOLDER FRAME (OPTIONAL)

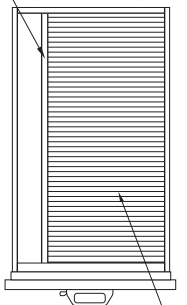

LETTER FILING FRONT TO BACK

SIDE VIEW:

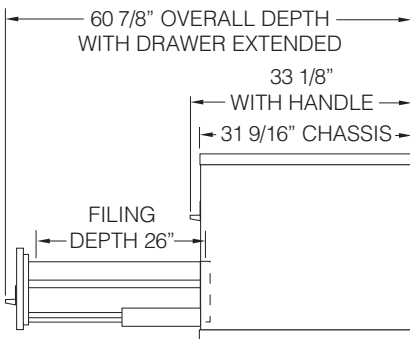

MODEL 2-2131-C:  
383 lbs (avg. ship wt.)

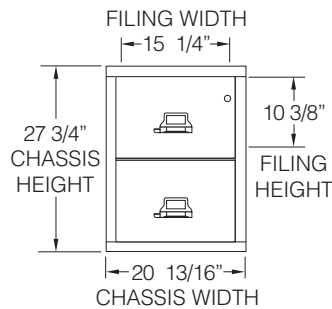

MODEL 3-2131-C:  
526 lbs (avg. ship wt.)

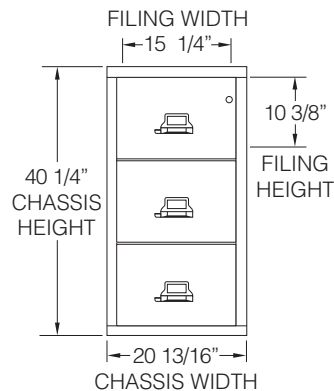

MODEL 4-2131-C:  
664 lbs (avg. ship wt.)

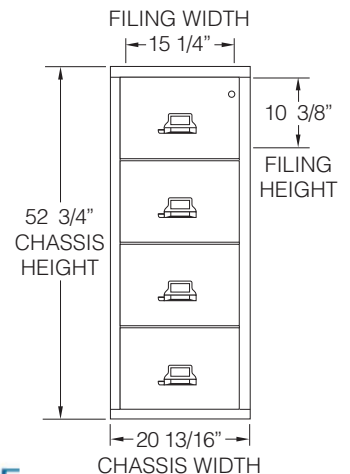

Dimensions  
±1/16 inch



WWW.ABE-Online.com  
TEL: 800-560-2242